

## LK-UP22X UPS Control Panel (3A)

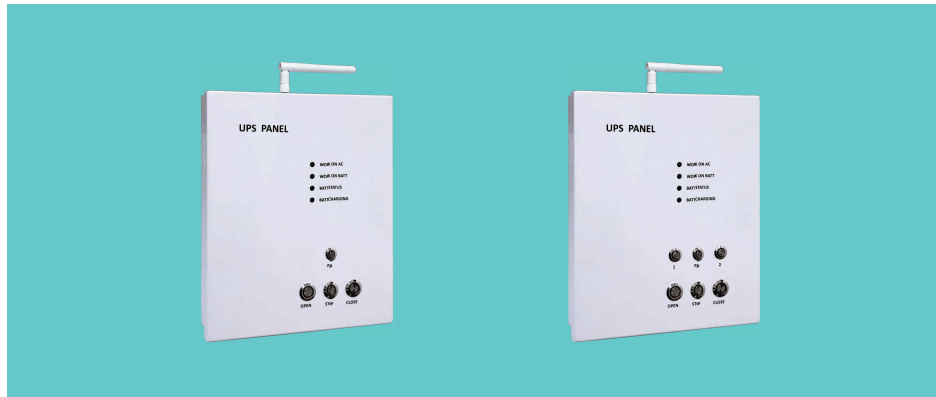

LK-UP221

LK-UP222

### Feature

- Used in window opener, curtain motor and door opener 24VDC motor control
- Power indicator/reset, Open/Stop/Close & channel selection buttons
- Built-in 24VDC/3A UPS, batteries output when AC power failure, batteries are charged automatically
- 100-240VAC international wide voltage input
- 4 working status LED indicators
- Single Channel, dual Channel outputs
- Cascade with LK-UP211, LK-UP22 and LK-UP24 control panel that achieves windows of zone control and group control
- Can handle external input signal of manual switch, remote control, timer, smoke /gas/ rain /temperature /humidity sensors
- Output fire feedback signal to fire centre
- Compatible with all LinkAYL remote
- Inching mode and continued-run mode settable
- With stroke memory function

### Ordering code

Model	Power(W)	Channel	Vin(VAC)	Vout(VDC)	Frequency	Size(mm)
LK-UP221	72	1	100-240	24	433.92MHz	242*200*56mm
LK-UP222	72	2	100-240	24	433.92MHz	242*200*56mm

### Application

Model	LK-SCE-D	LK-LCD	LK-TC	LK-L36A	LK-L36B	LK-L38AT	LK-L38AF
LK-UP221	3	2	1	2	2	2	1
LK-UP222	3	2	1	2	2	2	1

### Dimension

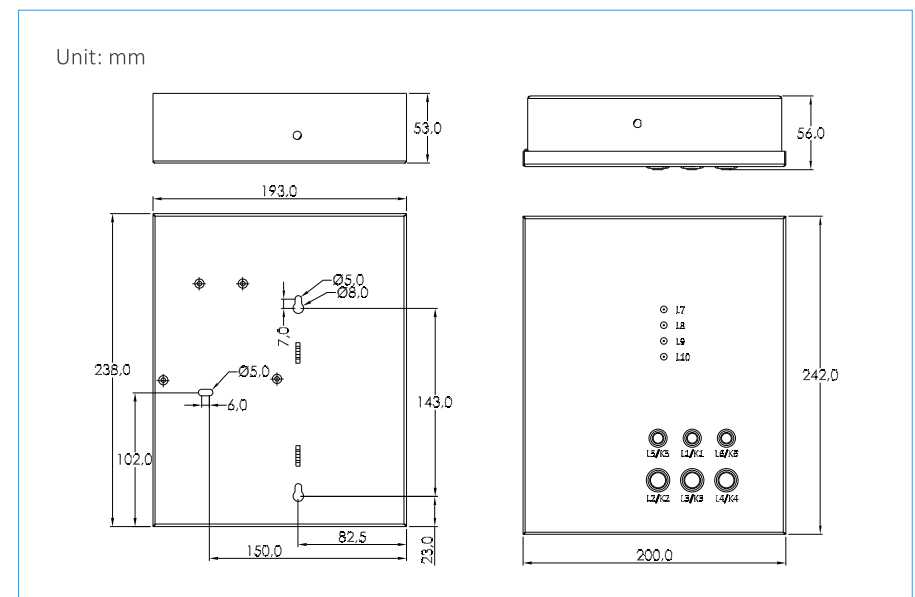

## LK-UP22X UPS Control Panel (3A)

### LED/KEY

LED/KEY	Color	Status	Function
L1 / K1	Blue	On/Off	AC power, Reset
L2 / K2	Green	On/Off/Flash	Open
L3 / K3	Red	On/Off	Stop
L4 / K4	Yellow	On/Off	Close
L5 / K5	Blue	On/Off	Channel 1
L6 / K6	Blue	On/Off	Channel 2
L7	Red	On/Off	Working on AC
L8	Green	On/Off	Working on battery
L9	Yellow	On/Off/Flash	Battery status
L10	Blue	On/Off	Battery charging

### UPS description

- When working on AC power, L7 is on, outputs 24V/3A to device, charge batteries, L10 is on. It automatically stops charging when the batteries are full, L10 is off
- When AC power failure, batteries automatically work for the load to ensure that the device does not stop or restart, L8 is on
- Switch to AC mode whenever AC power on, without manual intervention
- Battery voltage is lower than 22V, L9 is on. Battery voltage goes up to 22V, L9 is off. Batteries stop output when voltage is lower than 20V. When the batteries are faulty, L9 flashes and will turn off after fault removal

### Battery dimension

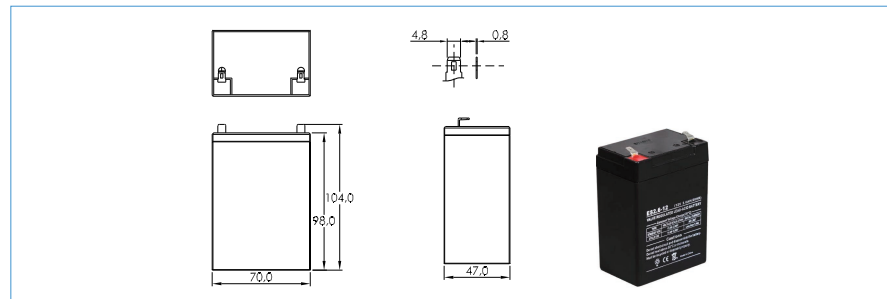

### Terminal

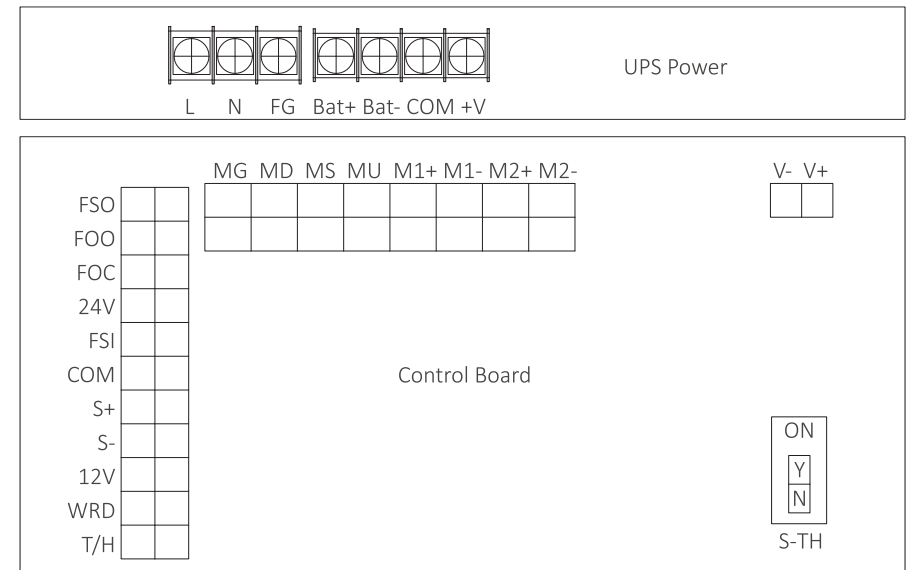

Symbol	Description	Symbol	Description
L	AC live wire	MD	Manual switch down
N	AC null wire	MG	Manual switch GND
FG	AC earth wire	FSO	Fire signal output
Bat+	Battery positive	FOO	Fire output NO
Bat-	Battery positive	FOC	Fire output NC
COM	24VDC output negative	24V	24VDC+ output
+V	24VDC output positive	FSI	Fire signal input
24VDC+	24VDC input positive	COM	Sensor COM
24VDC-	24VDC input negative	S+	Slave control up
Mx +	24VDC motor positive	S-	Slave control down
Mx-	24VDC motor negative	12V	DC12V+ output
MU	Manual switch up	WRD	Rain sensor down
MS	Manual switch stop	T/H	T/H signal

## LK-UP22X UPS Control Panel (3A)

### ■ Control mode

- Controller has inching mode and continued-run mode which is default
- In the continued-run mode, press UP or DOWN button less than 1.5 seconds, the motor will run continuously, press UP or DOWN button more than 1.5 seconds, the motor will stop after running a very short moment
- In the inching mode, press UP or DOWN button less than 1.5 seconds, the motor will stop after running a very short moment, press UP or DOWN button more than 1.5 seconds, the motor will run continuously
- Only the manual buttons on the panel, manual switch, remote control and cascade signal have inching mode
- Keep pressing both of UP and STOP button on the controller for 5 seconds, LEDs flash 3 times and turn off it's inching mode for the controller, repeat the operation the controller turns to continued-run mode

### ■ Manual control

- After power on all the LEDs light for 1 second and turn off, the power indicator LED normally on
- Press reset button, all the LEDs light for 1 second and turn off, reset successfully
- L2 will be explosion-flashing after controller receives fire signal
- External manual switch is equivalent to controller panel switch
- The maximum running time of the motor is 5 minutes

### □ Group control

- By default, L1 is normally on, the rest LEDs are off as group control status
- Press UP button, the windows open, LED turns on, turns off after 5 seconds
- Press DOWN button, the windows close, LED turns on, turns off after 5 seconds
- Press STOP button, the motors stop, LED turns on, LED turns off after 1 second

### □ Channel control

- Press channel selection keys the corresponding LED lights, channel selected
- Press the channel selection button again or no operation on controller thin 10 seconds, LED turns off, channel unselected
- In the process of opening/closing the current window, you can select another channel(s) to drive the window

### ■ Remote control

- The controller encodes by 433MHz learning code, can store 10 sets of transmission codes
- The controller defaults to multiple channel, single channel controller has the same way as multiple channel one

### □ Matching code

- Power the controller on, choose the channel(s) you want to set, can be set to any combination
- Pressing STOP button on controller for 5 seconds
- LED flashes 3 times and turns off
- Choose the channel you want to set on the remote
- Press UP within 15 seconds
- LED flashes 3 times and turns off
- Code matched successfully

### □ Clearing single code

- Power the controller on
- Keep pressing STOP key on the controller for 5S
- LED flashes 3 times and turns off
- Press DOWN button on the remote within 15 seconds
- LED flashes 3 times and turns off
- Code cleared successfully

### □ Clearing all codes

- Power controller on
- Pressing STOP /DOWN button on the controller for 5 seconds
- LEDs flash 3 times and turn off
- All the codes will be deleted after this operation

## LK-UP22X UPS Control Panel (3A)

### ■ Cascaded control

- Can be used as a master controller, a slave controller or play a dual role of master & slave controller at the same time
- As a master controller, connects to the motors or slave controllers to drive them
- As a slave controller, input terminals S+ and S- are connected to the output terminals M+ and M- of the master controller to receive the instructions to drive motors, or drive the motors independently
- Play a dual role of master & slave controller, not only controlled by higher-level controller, but also drive motors or lower-level controllers independently
- No matter master, slave or both, it can process all the external signals such as manual switch, remote and sensors
- Cascade use of the controller, if the master controller connected to an external sensor (such as smoke sensor, wind and rain sensor, etc.), the slave controller **MUST NOT** use inching mode, in case the master controller received the smoke signal to open the window, the slave controller will open the window for a very short moment and stop

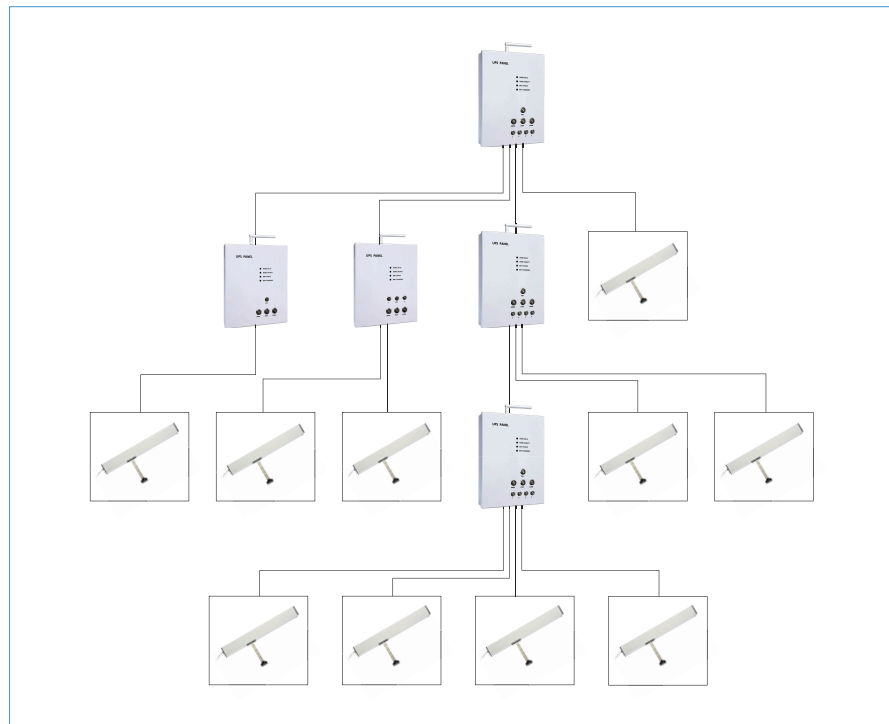

### ■ Signal control

- Manual signal. Control the window by the buttons on itself, external dry contact manual switch and RF remote
- Cascaded signal. As a master controller sends signal to the slave controller, can also be used as slave controller to receive the signal from the master controller to drive the window
- Fire signal. Capable of receiving a signal from fire center, smoke sensor, gas detector open the window automatically, send feedback signal to fire centre
- Rain signal. After receiving the signal of rain sensor close the window
- Temperature/humidity signal. Control the window by processing external temperature/humidity sensor

### □ Signal and priority

Priority	Signal	Device
1	Manual signal	Panel buttons, manual switch, remote, master controller
2	Fire signal	Smoke sensor, gas detector
3	W/R signal	Wired wind rain sensor
4	T/H signal	Temperature sensor, humidity sensor

### □ Reset and shielding

- After manual signal processed controller receives input signal in real time
- After processing the signal from fire centre, smoke sensor or gas detector, the controller immediately shields all the input signals, the controller must be reset by pressing K1 manually
- After wired rain sensor signal processed, the controller shields lower priority signal, only receives the higher priority signal until reset or manual signal processed
- After T&H sensor signal processed, the controller is in the reset state
- If the controller is not connected to a temperature and humidity sensor, the T/H port must be shielded (put option switch to "Y" position)

## LK-UP22X UPS Control Panel (3A)

### ■ Stroke memory

- The controller can set and memorize the opening stroke. Upon the stroke set, the window opening signal is triggered once, the motor will run the memorized stroke one time
- The default memorized stroke runs for 5 minutes
- Press both of UP /DOWN buttons on the controller for 3 seconds, LEDs flash 3 times and off, successfully entered the stroke memory setting state
- In the stroke memory setting state, the manual keys are forced to the continued-run mode, the remote control keys are forced to the inching mode
- Select the channel(S) to be set, the default is all selected, all the channel indicators light. Press the channel selection key(s), the indicators light, press the channel selection key(s) again the indicator is off, it is deselected. The setting is invalid without operation in 15 seconds
- After the channel selected, determine the stroke that needs to be memorized by pressing the manual key or the remote control key by moving or jogging
- The memorized stroke can be set to one channel or any combination of channel
- MAfter the memorized strokes determined, turn on all the channel indicators for setting the memorized stroke. Press both of UP /DOWN buttons on the controller for 3 seconds, LEDs flash 5 times and off, the memorized strokes of all channels set successfully and exit the stroke memory setting state, manual buttons and remote control buttons restored to the original mode
- In stroke memory setting state, no operation is performed within 15 seconds, LEDs flash 3 times slowly and off, the stroke memory setting state is automatically exited, and the last memorized stroke is retained
- Stroke memory can be set repeatedly. The controller only retains the last successful stroke value and automatically clears the previous one
- In stroke memory setting state, press both of STOP /DOWN buttons on the controller for 3 seconds LEDs flash 3 times the memorized stroke is deleted and restored to the default output for 5 minutes
- When the memorized strokes of master controller and slave controller are not the same, the master controller will run its own memorized stroke. The slave controller will run the shorter stroke when it receives the cascade signal from the master controller
- The memorized stroke set for each channel is retained in case the controller is powered down or reset
- When closing the window, the output time is 5 minutes

### ■ Installation instruction

- Please read the following instructions carefully before installing this product
- The control system must be installed by the professional
- The main power must be cut off before wiring to ensure safe operation
- Two 12V 2.6Ah batteries connected in series
- Please confirm positive and negative polarities before turning on the batteries to ensure that it cannot be reversed
- The controller does not contain batteries, please purchase with correct size and specifications
- Control panel cannot be installed outdoors
- Maximum output power MUST NOT exceed the total rated power of the controller
- Do not use metal objects to touch or cover the controller, otherwise it will affect the remote control signal reception
- The maximum transmission distance of the wireless signal can reach 50 meters or more in the open condition
- The distance between the controller and ground should be more than 1.5 meters
- The distance between the controller and ceiling should be more than 0.3 meters
- The distance between the controller and motor should be more than 1.5 meters
- Avoid static interference and prevent static damage to electronic components
- Please use the soft wire and cable, after installation ensure that the cable carrier is not affected by the longitudinal tension
- An external sensor must use a product that is compatible with this controller
- Non-professionals is not allowed to disassemble the controller. If any function is unusual, please contact your local dealer

### ■ Troubleshooting

No.	Symptom	Solution
1	LED flashes, receiver shut down	1. Check the connection of wires 2. Check the receiver setting
2	LED on the transmitter is off or weak	1. Make sure the right installation of the battery 2. Change the battery
3	The transmitter and the receiver work well, the motor does not work	1. Check the wiring of motor 2. Make sure the motor no failure