

LK-MR53X Actuator Controller



LK-MR531 LK-MR533 LK-MR535 LK-MR536

LK-MR532

Feature

- Made by low-power and high-speed CMOS technology
- Strong anti-interference ability
- Manual control and remote control
- Can be controlled by external sensor, such as rain or smoke sensor
- Can store 16 transmitter signals
- Motor protection, cutting power off automatically in 5 minutes
- Working temperature is -10~+65°C

Ordering code

Model	Vin	Vout	Iout	Frequency	Sensitivity	Size
LK-MR531	120/230VAC	120/230VAC	0.2A	433.92MHz	-100dBm	86*86*35mm
LK-MR532	120/230VAC	120/230VAC	0.1A*2	433.92MHz	-100dBm	86*86*35mm
LK-MR533	100-240VAC	24VDC	3A	433.92MHz	-100dBm	86*86*35mm
LK-MR535	100-240VAC	24VDC	1.5A	433.92MHz	-100dBm	86*86*35mm
LK-MR536	24VDC	24VDC	10A	433.92MHz	-100dBm	86*86*35mm

Button

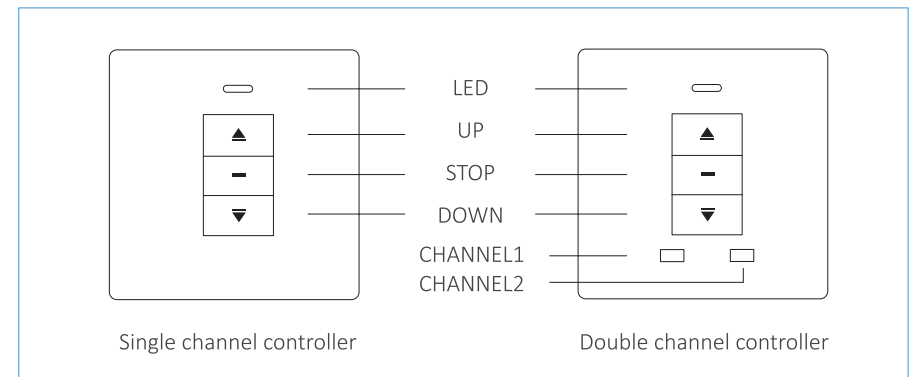

Terminal

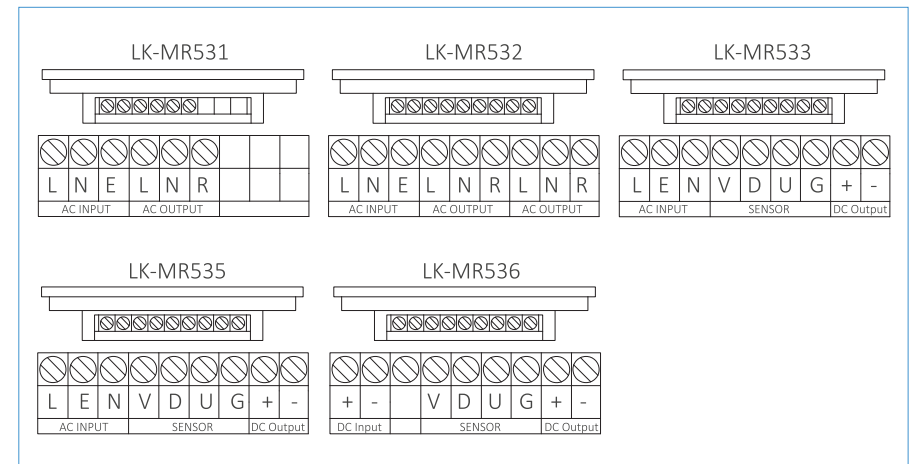

AC Input		AC Output		DC Input/ DC Output		Sensor	
L	Live Wire	L	Forward	+	24VDC Positive	V	12VDC+
N	Null Wire	R	Reverse	-	24VDC Negative	D	Down
E	Earth Wire	N	Neutral			U	Up
						G	Com

LK-MR53X Actuator Controller

■ Operation description

- Setting method of single channel receiver is as same as double channel receiver
- Before setting multi channel transmitter, please choose the right channel which you want to program
- Maximum running time of motor is 5 minutes

■ Matching code

- Power the controller on
- Keep pressing STOP button on the controller for 5 seconds
- Press UP button on the remote within 15 seconds
- LED flashes 3 times and turns off
- Codes are matched successfully

■ Clearing single code

- Power the controller on
- Keep pressing STOP button on the controller for 5 seconds
- Press DOWN button on the remote within 15 seconds
- LED flashes 3 times and turns off
- Code is cleared successfully

■ Clearing all code

- Power the controller on
- Keep pressing both of STOP and DOWN buttons on the controller for 5 seconds
- LED flashes 3 times and turns off
- All the codes matching the channel will be deleted after this operation

■ Changing direction

- Power the controller on
- keep pressing both of UP and DOWN buttons on the controller for 5 seconds
- LED flashes 3 times and turns off
- Directions changed successfully

■ Inching mode

- Power the controller on
- Keep pressing both of UP and STOP buttons on the controller for 5S
- LED flashes 3 times and turns off, setting is done
- Repeat the action, it turns to normal mode
- It can work continuously when pressing the UP /DOWN for more than 1.5 seconds

■ Installation note

- Please observe the following provisions in accord with standard of effective power
- Do not use metal objects to touch or shade the receiver, avoid the interference of receiving signals
- Transmit distance: 50 meters without obstacle, 30 meters through wall
- The installation distance between the receiver and ground, between the receiver and the ceiling is more than 1.5 m, between two receivers is more than 0.2 m
- The main power supply must be cut off before installing wiring
- In order to prevent electrostatic interference, must ensure that the receiver is effectively grounded
- After the installation, ensure that the receiver and cable are not affected by tension

■ Troubleshooting

No.	Symptom	Solution
1	LED flashes, receiver shut down	1. Check the connection of wires 2. Check the receiver setting
2	LED on the transmitter is off or weak	1. Make sure the right installation of the battery 2. Change the battery
3	The transmitter and the receiver work well, the motor does not work	1. Check the wiring of motor 2. Make sure the motor no failure